

▶ WORKSHOP EQUIPMENT

LEADING AUTOMOTIVE CUSTOMER SERVICE

Vehicle Lifts · Tire Equipment · Lube Solutions · Exhaust Extraction Systems



vrelyen

licensed by

ISTOBAL



▶ MANUFACTURING OF GARAGE EQUIPMENT AND CUSTOMER SERVICE AT YOUR DISPOSAL

Velyen is synonymous of guarantee because offers you a network of very competitive and highly qualified technical staff. With more than 60 official partners and after sales services around the world, Velyen takes care of a sophisticated and experienced after-sale services network.

Velyen group has over 35,000 m² in Valencia (l'Alcúdia, Almussafes, Náquera and Carlet) and we have a staff of more than 250 employees specialized in manufacturing integrated processes (machining, stamping, tooling, laser welding and assembly).

Updating our products and looking for future garage equipment are our progress compromise. Through a large investment of our Research, Development and Innovation department, promotes and updates product range to cover full needs of the workshop and be ahead to market leaders.



▶ *Lube*



▶ *Exhaust Extraction Systems*



▶ *Tire changers, wheel balancers and wheel aligner*



▶ *Automotive and Heavy Duty Lifts*



▶ MAINTENANCE AND REPAIR SERVICE WITHOUT WORRIES

Our clients have always been Velyen's first focus of attention and we have promoted for them some services that in most of cases have been pioneering and differentiating. Servi-Velyen services and profits:

- ▶ ***You will work better and safer, since we will be at your disposal at anytime.***
- ▶ ***You will obtain solutions and answers to your concrete requirements.***
- ▶ ***You will improve economic, labour, and progress health in garage equipment.***

Velyen recommends to contract the maintenance services directly with the Official Technical Service in each country to obtain a better performance and long-life of the equipment.

Training:

It is a direct service to all our partners and distributors. Our specialist's personnel in each area will support and train all technical or commercial networks about:

Commercial Support

Values of our machines, comparative with competitors, tools to increase sales together, stocks proposal, etc.

Technical Assistance

Methodology and tools to offer a differentiating and professional after sale services (installation, maintenance, repairs and warranty).

Spare Parts Service

Quick and effective supply of original spare parts according to the strictest European Law. Parts delivery guaranteed for over 10 years

▶ **TURNKEY INSTALLATIONS**

▶ DISPENSING AND COLLECTION OF OIL AND OTHER FLUIDS

velyen licensed by **ISTOBAL**

Automotive Lifting Quality

EXAMPLE OF TURNKEY INSTALLATION

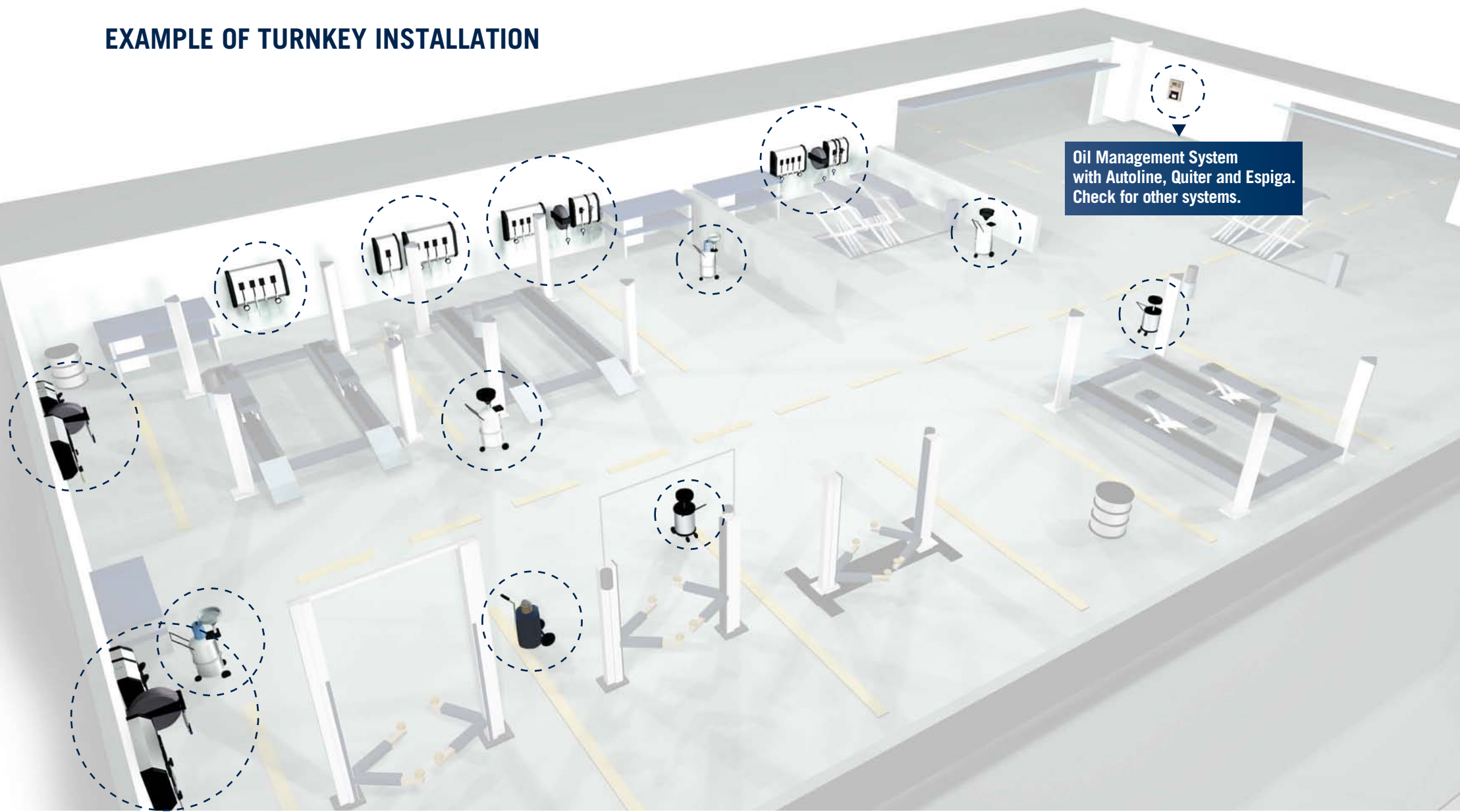

Oil Management System
with Autoline, Quiter and Espiga.
Check for other systems.

► DISPENSING AND COLLECTION OF OIL AND OTHER FLUIDS

velyen licensed by **ISTOBAL**

Automotive Lifting Quality

SUCTION/DRAINER UNIT 90 LITRES – PNEUMATIC DISCHARGE

MOD. VELYEN | 5010190

- Mobile equipment
- Tank capacity of 90 l.
- Pressure control valve
- Extraction capacity of 60 l.
- The tank drain is performed pneumatically.
- Bowl capacity 13 l.

Advantages:

- Quick aspiration.
- Extraction of oil by gravity or suction
- Collection cleaner and more efficient.



COMPONENTS

Set of suction probes

Funnel suitable for all vehicles

Transparent Chamber to display the recovered oil quality as well as quantity

Equipped with four wheels, two swiveling

Oil Level Gauge

Suction and discharge hoses of 2 m.

► DISPENSING AND COLLECTION OF OIL AND OTHER FLUIDS

velyen licensed by **ISTOBAL**

Automotive Lifting Quality

DRAINER UNIT 90 LITRES – PNEUMATIC DISCHARGE

MOD. VELYEN | 5685090

- Mobile equipment
- Tank capacity of 90 l.
- Extraction capacity of 60 l.
- The tank drain is performed pneumatically.
- Bowl capacity 13 l.
- Oil extraction by gravity.

Advantages:

- Quick aspiration.
- Collection cleaner and more efficient.



COMPONENTS

Funnel suitable for all vehicles

Equipped with four wheels, two swiveling

Oil Level Gauge

Discharge hoses of 2 m.

▶ EXHAUST EXTRACTION SYSTEMS

velyen licensed by **ISTOBAL**

Automotive Lifting Quality

TURNKEY PROJECTS: CUSTOMIZED SOLUTIONS ACCORDING TO CUSTOMER REQUIREMENTS



MOBILE EXHAUST EXTRACTION UNIT

MOD. VELYEN | 4GC0010

- Mobile equipment without installation
- ON/OFF switch
- Adjustable height
- 10 m hose, Ø100 mm
- Rubber nozzle and clamp
- Metal steel sheet fan 1000m³/h (prev. max 105 mm H200)
0,37 KW 0,5 HP-230/400 V-50Hz

▶ **VEHICLE LIFTS**

HYDRAULIC 2-POST LIFT WITH SEMI-BASE 4.000 KG

MOD. VELYEN | 4EB1100MX



- Homologated and certified product according to the European Machinery Directive 98/37/CE and Harmonized Standards EN 1493:1999.
- Reinforced carriages and arms for better safety.
- 3-section arms with lower pick-up height 75 mm.
- Safety device on lifting arms against toe-trapping.
- Automatic arms locking.
- Nylatron sliders with low coefficient of friction and wear.
- Control box with ON/OFF switch and independent UP and DOWN pushbuttons.
- Single point release of safety locks by lever.
- Carriage synchronization and safety against obstacles by wires.
- Two heavy-duty chains drive carriages for a total security.
- Automatic safety shutdown in case of breakage of chains or wires.
- Semi-base low profile: 34 mm height.
- Two pad extensions of 50&140mm permit the loading of any type of vehicle.



Distance between posts	2855 mm
Load Capacity	4000 Kg
Pick up Height	75 mm
Pads Height	50/140 mm
Lifting Height	1880 mm
Lifting Speed	45"
Arms Length (min-max)	730-1370 mm
Overall Width	3520 mm
Motor	3 phase 230/400 V - 50/60 Hz. 2.2 KW

Single Phase Version: 4EB1151

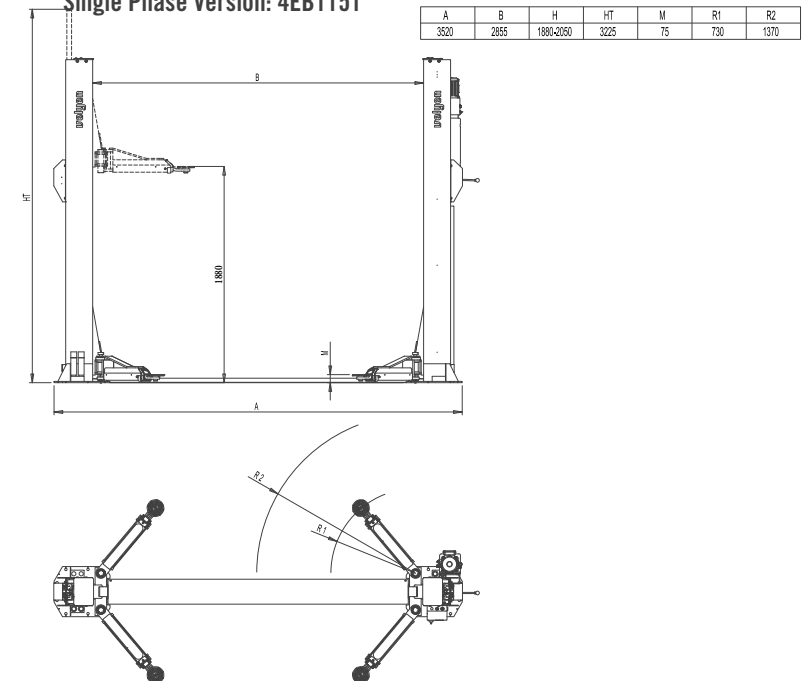

HYDRAULIC 2-POST LIFT WITH SEMI-BASE 4.000 KG

MOD. VELYEN | 4EB1100AMX



- Reinforced carriages and arms for better safety.
- 3-section arms with lower pick-up height 75 mm.
- Safety device on lifting arms against toe-trapping.
- Automatic arms locking.
- Nylatron sliders with low coefficient of friction and wear.
- Control box with ON/OFF switch and independent UP and DOWN pushbuttons.
- Single point release of safety locks by lever.
- Carriage synchronization and safety against obstacles by wires.
- Two heavy-duty chains drive carriages for a total security.
- Automatic safety shutdown in case of breakage of chains or wires.
- Semi-base low profile: 34 mm height.
- Two pad extensions of 50&140mmpermittheloadingofany type of vehicle.



Distance between posts	2855 mm
Load Capacity	4000 Kg
Pick up Height	75 mm
Pads Height	50/140 mm
Lifting Height	1880 mm
Lifting Speed	45"
Arms Length (min-max)	730-1370 mm
Overall Width	3520 mm
Motor	3 phase 230/400 V - 50/60 Hz. 2.2 KW

Single Phase Version: 4EB1151AMX

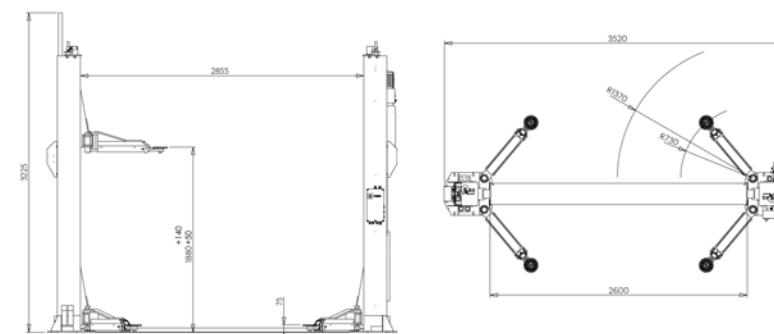

HYDRAULIC 2-POST LIFT BASELESS 4.500 KG

MOD. VELYEN | 4EC1000MX



- Homologated and certified product according to the European Machinery Directive 98/37/CE and Harmonized Standards EN 1493:1999.
- Reinforced carriages and arms for maximum safety.
- Adjustable 3-stage arms with minimum pick up height 90 mm.
- Single point release of safety locks by lever make this lift easy and safe to use. Automatic arm locking system.
- Nylatron sliders with low coefficient of friction and wear ensure a stable and soft lifting and lowering movements.
- Control box equipped with general switch ON/OFF and independent UP and DOWN pushbuttons.
- Toe guard device on lifting arms.
- Carriage synchronization and safety against obstacles on lowering by wire ropes.
- Two direct drive hydraulic cylinders ensure the maximum stability.
- Two pad extensions 70 & 140 mm permit the lifting of any type of vehicle.



Distance between columns	2970 mm
Load capacity	4500 Kg
Minimum height	90 mm
Pad extensions height	70/140 mm
Lifting height	1870 mm
Lifting time	45"
Arms length (min-max)	820-1300 mm
Overall width	3685 mm
Motor	3 Phases 230/400 V - 50/60 Hz. 2.2 KW

Single phase version: 4EC1051

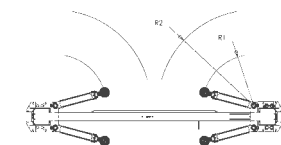
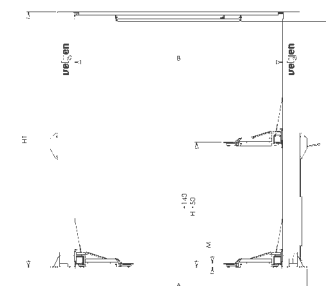

A	B	C	R1	R2	M	R1	R2
3085	2700	970	1000/1020	420/2110	70	220	300

ELECTROMECHANICAL 2-POST LIFT ASYMMETRIC BASELESS 3.500 KG ELECTRONIC SYNCHRONIZATION

MOD. VELYEN | 4EC1800



- Homologated and certified according to the new European Machinery Directive 2006/42/CE and Harmonized Standards EN 1493:2010.
- Asymmetric arms to permit an easier opening of doors. Equipped with telescopic arms and double screwed pad suitable to lift any type of vehicle.
- SCS : New integrated informative system of Self-Diagnosis.
- Electronic synchronization through inductive detectors.
- Low maintenance: Automatic and permanent lubrication of spindles and nuts.
- Maximum stability: High quality sliders to guarantee a perfect stability of the arm carriages.
- High resistance spindles. Manual lowering of the vehicle in case of energy absent.



► OPTIONAL EXPRESS-PADS

Distance between columns	2695 mm
Load capacity	3500 Kg
Pick up height	95 mm
Lifting height	2000 mm
Lifting time	45 s
Arms length	Short: 620-1240 mm / Long: 925-1540 mm
Overall width	3490 mm
Overall height with overhead conduit included	4040 mm
Motor	3 phase 230/400 V - 50/60 Hz. 2 x 2,4 KW

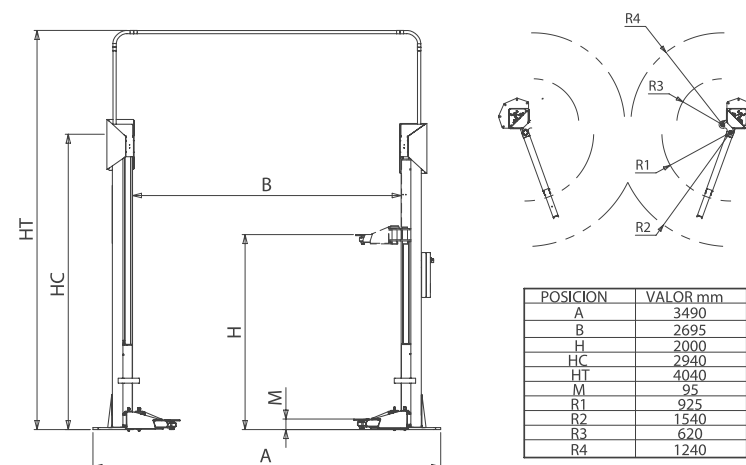

HYDRAULIC 4-POST LIFT 4.000 KG

MOD. VELYEN | 4ED0400



- Electro-hydraulic lifting system operating over a simple effect cylinder.
- Innovative design of columns without longitudinal welds.
- Platform locking system operated automatically by electromagnets.
- Automatic release of safety wedges by pushing DOWN button.
- Movable scissor jacking beam available an order.
- Front and rear stop safety against sliding.
- Safety system against obstacles, cable breakdown or looseness.
- Hydraulic cylinder with control valve of lowering speed.
- Safety valve against overpressure of the hydraulic system.
- Motor equipped with thermal detector against overheating.
- Pushbuttons at 24 V, type "dead man".



► OPTIONAL KIT MOT4 ATL

Load capacity	4000 Kg
Platforms length	4450 mm
Platforms width	560 mm
Width between columns	2670 mm
Distance between platforms	(min-max) 690-1015 mm
Drive on height	150 mm
Lifting height	1700 mm
Lifting time	35"
Overall length	5380 mm
Overall width	3035 mm
Motor	Trifásico 230/400 V - 50/60 Hz. 2.2 KW

Versión monofásica: 4ED0451 (1.9 KW - 230 V)

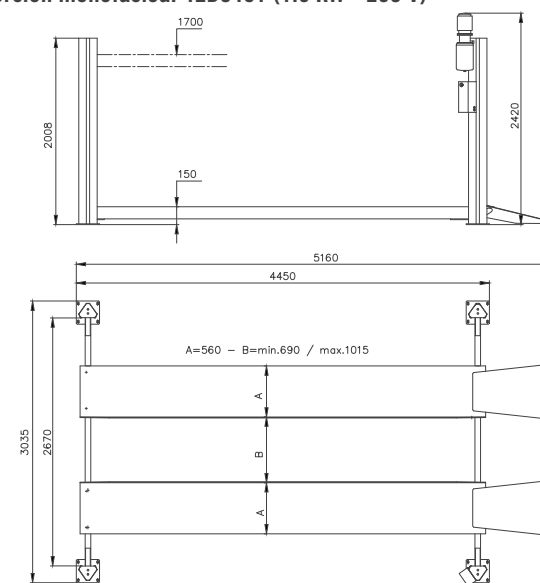

HYDRAULIC 4-POST LIFT - 4.000 KG WIDER FOR 3D ALIGNMENT

MOD. VELYEN | 4ED0400N



- Electro-hydraulic lifting system operating over a simple effect cylinder.
- Innovative design of columns without longitudinal welds.
- Platform locking system operated automatically by electromagnets.
- Automatic release of safety wedges by pushing DOWN button.
- Movable scissor jacking beam available on order.
- Smooth platforms.
- Safety system against obstacles, cable breakdown or looseness.
- Hydraulic cylinder with control valve of lowering speed.
- Safety valve against overpressure of the hydraulic system.
- Motor equipped with thermal detector against overheating.
- Pushbuttons at 24V, type "dead man".



Load capacity	4000 Kg
Platforms length	4450 mm
Platforms width	560 mm
Width between columns	2900 mm
Distance between platforms	(min-max) 690-1245 mm
Drive on height	150 mm
Lifting height	1800 mm
Lifting time	35"
Overall length	5380 mm
Overall width	3265 mm
Motor	3 Phase 230/400 V - 50/60 Hz. 2.2 KW

Single phase version: 4ED0451N (1.9 KW - 230 V)

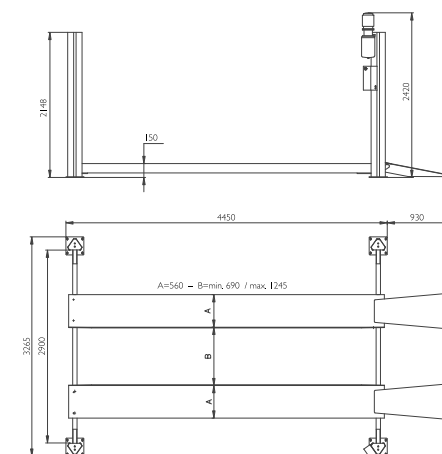

HYDRAULIC 4-POST LIFT 5.000 KG

MOD. VELYEN | 4ED0600



- Innovative design of columns without longitudinal welds
- Electro-hydraulic lifting system operated over a simple effect cylinder.
- Platform locking system operated automatically by electromagnets
- Safety system against obstacles, cable breakdown or looseness.
- Hidraulic cylinder with control valve of lowering speed.
- Safety valve against overpressure of the hydraulic system
- Motor equipped with thermal detector against overheating
- Pushbuttons at 24V., type "dead man", separated UP & DOWN buttons and ON/OFF switch locable by a padlock.
- Special protection on pulleys zone
- Smooth platforms
- Upper height limit switch.
- Automatic release of safety wedges by pushing DOWN button
- Special width between columns suitable for 3D alignment



Load Capacity	5000 Kg
Platforms length	5230 mm
Platforms width	580 mm
Width between columns	2900 mm
Distance between platforms	(min-max) 800-1210 mm
Drive on height	150 mm
Lifting height	1800 mm
Lifting time	35"
Overall length	6200 mm
Overall width	3265 mm
Motor	3 Phases 230/400 V - 50/60 Hz. 2.2 KW

Single phase version: 4ED0651 (1.9 KW - 230 V)

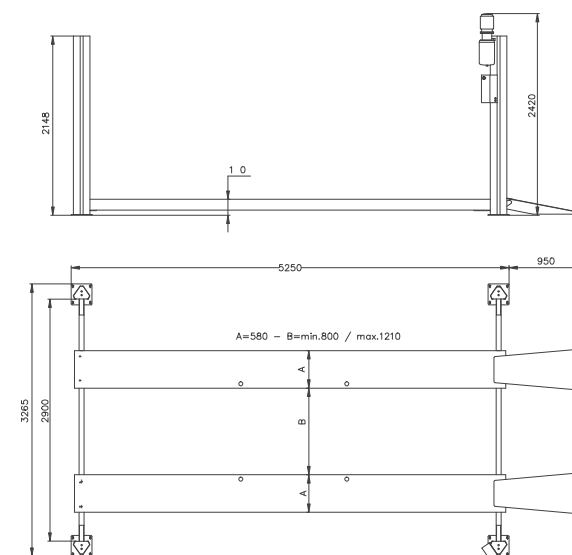

HYDRAULIC 4-POST LIFT 5.000 KG

MOD. VELYEN | 4ED0600N



- Innovative design of columns without longitudinal welds
- Electro-hydraulic lifting system operated over a simple effect cylinder.
- Platform locking system operated automatically by electromagnets
- Safety system against obstacles, cable breakdown or looseness.
- Hydraulic cylinder with control valve of lowering speed.
- Safety valve against overpressure of the hydraulic system
- Motor equipped with thermal detector against overheating
- Pushbuttons at 24V., type "dead man", separated UP & DOWN buttons and ON/OFF switch locable by a padlock.
- Special protection on pulleys zone
- Smooth platforms
- Upper height limit switch.
- Automatic release of safety wedges by pushing DOWN button
- Special width between columns suitable for 3D alignment



► OPTIONAL KIT MOT7 ATL

Load Capacity	5000 Kg
Platforms length	5230 mm
Platforms width	630 mm
Width between columns	2636 mm
Distance between platforms	min-max 725-940 mm
Drive on height	150 mm
Lifting height	1835 mm
Lifting time	35"
Overall length	5985 mm
Overall width	3000 mm
Motor	3 Phases 230/400 V - 50/60 Hz. 2.2 KW

Single phase version: 4ED0651N (1.9 KW - 230 V)

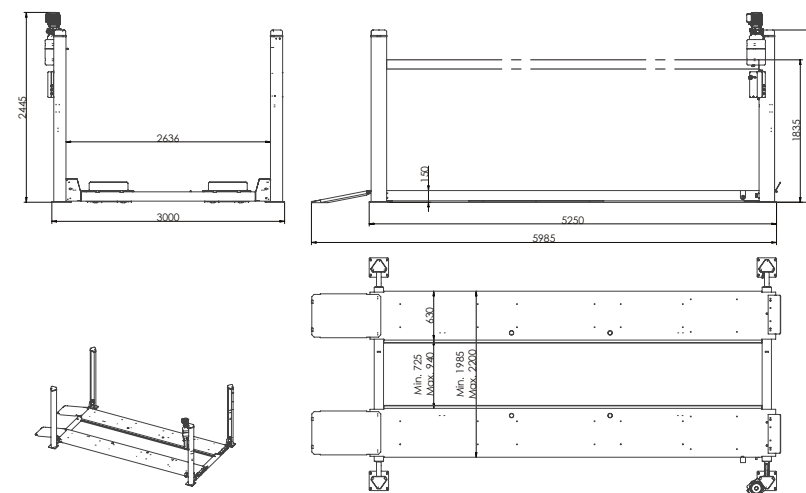

DOUBLE SCISSOR LIFT 3.000 KG - LOW PROFILE: 105 MM

MOD. VELYEN | 4EE1400



- Strong structure of 4 cylinders to ensure two independent oil circuits: hydraulic safety.
- Additional mechanical safety (ratches) against lowering released by pneumatic device.
- Low profile platforms are suitable for special or tuned vehicles.
- Equipped with flow control valve to adjust the lowering speed.
- The automatic bleeding of hydraulic circuits can be done easily by the operator without any type of technical assistance.
- Single phase version (230V) available on order.
- Safety valve against over-pressure
- Suitable for surface or in-ground installation.
- Free maintenance self-lubricating bushings mantenimiento
- Pushbuttons at 24V, type "dead man".
- Isolated ON/OFF switch lockable with padlock.



Load capacity	3.000 Kg.
Platforms Length	Min/max 1.550-2.115 mm
Platforms Width	635 mm
Drive on height	105 mm
Maximum lifting height	1.900 mm
Distance between platforms	720 mm
Overall length	2.118 mm
Overall width	1.990 mm
Motor	3 Phases 230/400 V - 50/60 Hz. 2.2 KW

Single phase version: 4EE1451

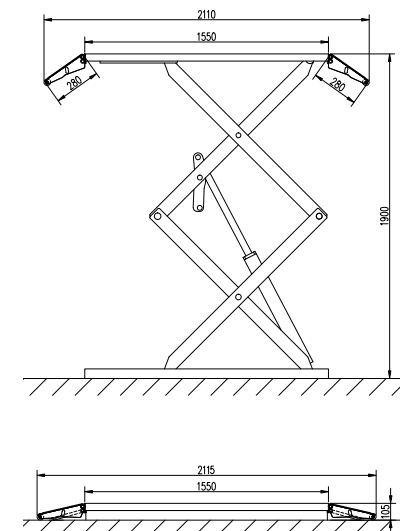

DOUBLE SCISSOR LIFT 3.500 KG · LOW PROFILE: 10 CM · AUTOMATIC BLEEDING

MOD. VELYEN | 4EE1300



- Strong structure of 4 cylinders to ensure two independent oil circuits: hydraulic safety.
- Low profile platforms are suitable for special or tuned vehicles.
- Suitable for surface or in-ground installation.
- The automatic bleeding of hydraulic circuits can be done easily by the operator without any type of technical assistance.
- Equipped with safety valve against over-pressure.
- Hydraulic system with safety device against unexpected uneven of platforms.
- Automatic safety stop at 300 mm from the floor and throughout the whole descent the lift will beep warning.
- High quality sliders guarantee a soft and stable lifting and lowering movement.
- Free maintenance self-lubricating bushings.
- Pushbuttons at 24V, type "dead man"
- Separated UP & DOWN pushbuttons and general switch lockable with padlock.
- Insolated ON/OFF switch · Safety system against obstacles on the lowering



Load Capacity	3.500 Kg.
Platforms Length	Min/max 1.550-2.115 mm
Platforms Width	635 mm.
Drive on height	105 mm
Maximum Lifting Height	1.960 mm
Distance between platforms	720 mm
Overall Length	2.115 mm
Overall Width	1.990 mm.
Motor	3 Phase 230/400 V - 50/60 Hz. 2.2 KW

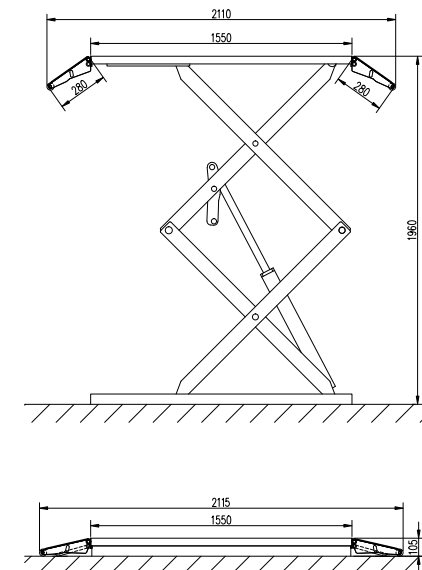

HIGH RAISE SCISSOR LIFT 4.500 KG

Suitable For Wheel Alignment · In-ground Or Surface Installation

MOD. VELYEN | 4EE0700



- Low friction sliding rear platforms with manual lockable in centered position and permitting a round movement in any direction.
- Alignment platforms with recesses to fit any size of front turning plates or play detector.
- Mechanical safety system against lowering with pneumatic release of safety wedges.
- Lighting equipment for night-work can be integrated in the main platforms like an optional.
- Safety system against obstacles on lowering.
- Hydraulic cylinder equipped with a flow valve to control the lowering speed.
- Hydraulic unit is provided with a safety valve against overpressure.
- Push buttons at 24V, type "Dead Man", separated "UP" & "DOWN" pushbuttons with ON/OFF switch lockable with a padlock.
- Height limit switches · Lowering speed control.
- Automatic safety stop on lowering against toe-trapping at 400 mm from the floor. To continue the descent is pressed the pushbutton DOWN again and an acoustic signal will sound until the final descent.
- Bearing pump 4.3 cm³/v, provided with gauge cap and a lowering electro-valve with manual control in case of energy absence.
- Joint shafts with maintenance free self-lubricating bushings.



MAIN LIFT

Cargo Capacity	4500 Kg
Platform Width	664 mm
Platform Length	5030 mm
Overall Length (ramps included)	5330 mm
Distance between Platforms	940 mm
Lifting Height	2040 mm
Foundation Depth	330 mm
Motor	3 Phase 400V 50/60 Hz. 2.2 KW

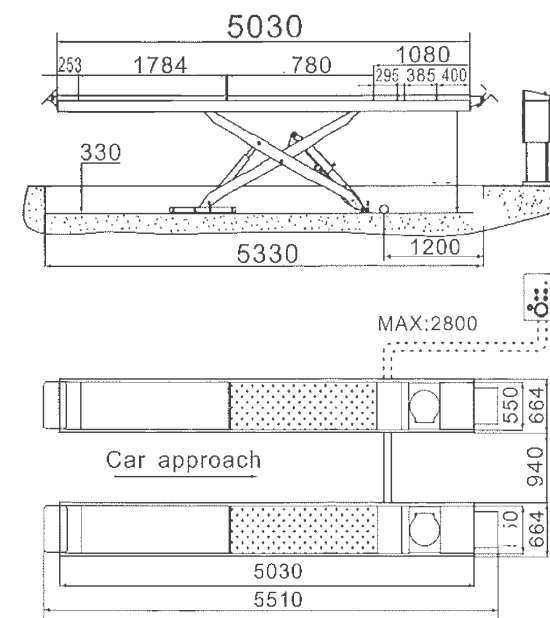

SCISSOR LIFT FOR WHEEL ALIGNMENT 4.000 KG FREE WHEELS SERVICE MOD. VELYEN | 4EE0500H



- Low friction sliding rear platforms with manual lockable in centered position and permitting a round movement in any direction.
- Alignment platforms with adjustable recesses to fit any size of front turning plates.
- Mechanical safety system against lowering with pneumatic release of safety wedges.
- Lighting equipment for night-work can be integrated in the main platforms like an optional.
- Safety system against obstacles on lowering.
- Hydraulic cylinder equipped with a flow valve to control the lowering speed.
- Hydraulic unit is provided with a safety valve against overpressure.
- Pushbuttons at 24 V, type “dead man”, separated “UP & DOWN” pushbuttons with ON/OFF switch lockable with a padlock.
- Height limit switch.
- Lowering speed control.
- Automatic safety stop on lowering against toe-trapping. Press again the DOWN pushbutton to continue the descent down to the floor. Throughout the whole descent, the lift will keep warning.
- Bearing pump 4.3 cm3/v, provided with a gauge cap and a lowering electro-valve with manual control in case of energy absence.
- Joint shafts with free maintenance self-lubricating bushings.



MAIN LIFT

Cargo Capacity	4000 Kg
Platform Width	620 mm
Platform Length	5030 mm
Distance between Platforms	920 mm
Lifting Height	2160 mm
Foundation Depth	330 mm
Motor	3 Phase 230-400V 50/60 Hz. 2.2 KW

FREE-WHEELS LIFT

Cargo Capacity	3500 Kg
Platform Length	1400 - 1800 mm
Platform Width	570 mm
Lifting Height	450 mm

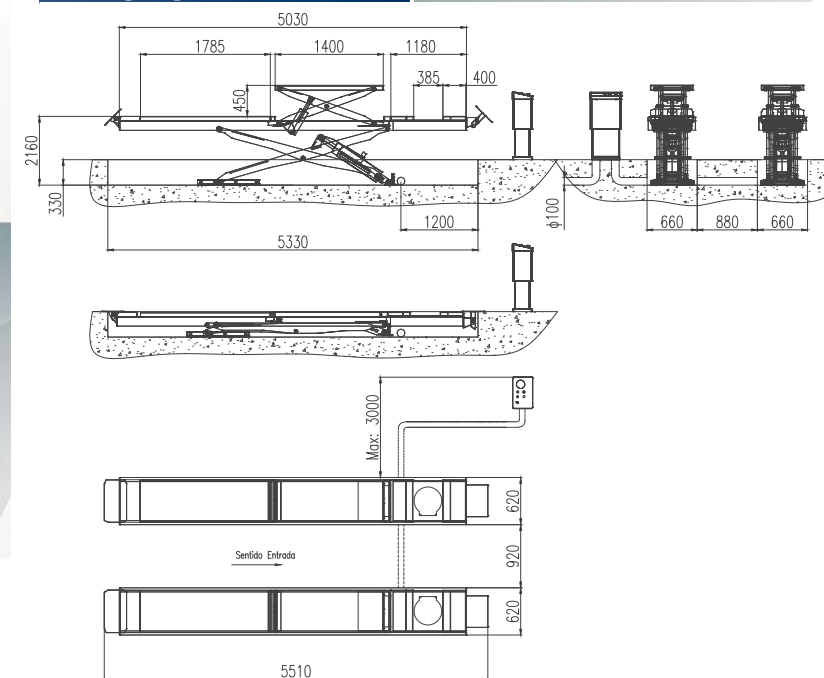

SCISSOR LIFT FOR WHEEL ALIGNMENT 4.000 KG FREE WHEELS SERVICE

MOD. VELYEN | 4EE0505H



- Low friction sliding rear platforms with manual lockable in centered position and permitting a round movement in any direction.
- Alignment platforms with adjustable recesses to fit any size of front turning plates.
- Mechanical safety system against lowering with pneumatic release of safety wedges.
- Lighting equipment for night-work can be integrated in the main platforms like an optional.
- Safety system against obstacles on lowering.
- Hydraulic cylinder equipped with a flow valve to control the lowering speed.
- Hydraulic unit is provided with a safety valve against overpressure.
- Pushbuttons at 24 V, type “dead man”, separated “UP & DOWN” pushbuttons with ON/OFF switch lockable with a padlock.
- Height limit switch.
- Lowering speed control.
- Automatic safety stop on lowering against toe-trapping. Press again the DOWN pushbutton to continue the descent down to the floor. Throughout the whole descent, the lift will beep warning.
- Bearing pump 4.3 cm³/v, provided with a gauge cap and a lowering electro-valve with manual control in case of energy absence.
- Joint shafts with free maintenance self-lubricating bushings.



MAIN LIFT

Cargo Capacity	4000 Kg
Platform Width	610 mm
Platform Length	4500 mm
Distance between Platforms	820 mm
Lifting Height	2160 mm
Foundation Depth	330 mm
Motor	3 Phase 230-400V 50/60 Hz. 2.2 KW

FREE-WHEELS LIFT

Cargo Capacity	3500 Kg
Platform Length	1400 - 1800 mm
Platform Width	570 mm
Lifting Height	450 mm

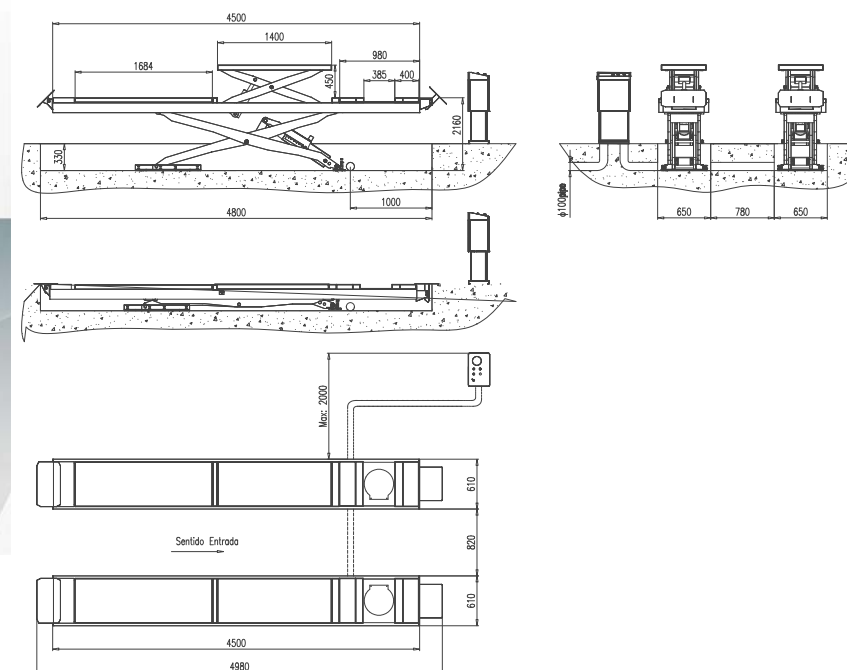

SCISSOR LIFT FOR WHEEL ALIGNMENT 5.000 KG FREE WHEELS SERVICE MOD. VELYEN | 4EE0600H



- Low friction sliding rear platforms with manual lockable in centered position and permitting a round movement in any direction.
- Alignment platforms with adjustable recesses to fit any size of front turning plates.
- Mechanical safety system against lowering with pneumatic release of safety wedges.
- Lighting equipment for night-work can be integrated in the main platforms like an optional.
- Safety system against obstacles on lowering.
- Hydraulic cylinder equipped with a flow valve to control the lowering speed.
- Hydraulic unit is provided with a safety valve against overpressure.
- Pushbuttons at 24 V, type “dead man”, separated “UP & DOWN” pushbuttons with ON/OFF switch lockable with a padlock.
- Height limit switch.
- Lowering speed control.
- Automatic safety stop on lowering against toe-trapping. Press again the DOWN pushbutton to continue the descent down to the floor. Throughout the whole descent, the lift will beep warning.
- Bearing pump 4.3 cm3/v, provided with a gauge cap and a lowering electro-valve with manual control in case of energy absence.
- Joint shafts with free maintenance self-lubricating bushings.



MAIN LIFT

Cargo Capacity	5000 Kg
Platform Width	620 mm
Platform Length	5030 mm
Distance between Platforms	800 mm
Lifting Height	2160 mm
Foundation Depth	330 mm
Motor	3 Phase 230-400V 50/60 Hz. 2.2 KW

FREE-WHEELS LIFT

Cargo Capacity	3500 Kg
Platform Length	1630 - 2150 mm
Platform Width	570 mm
Lifting Height	450 mm

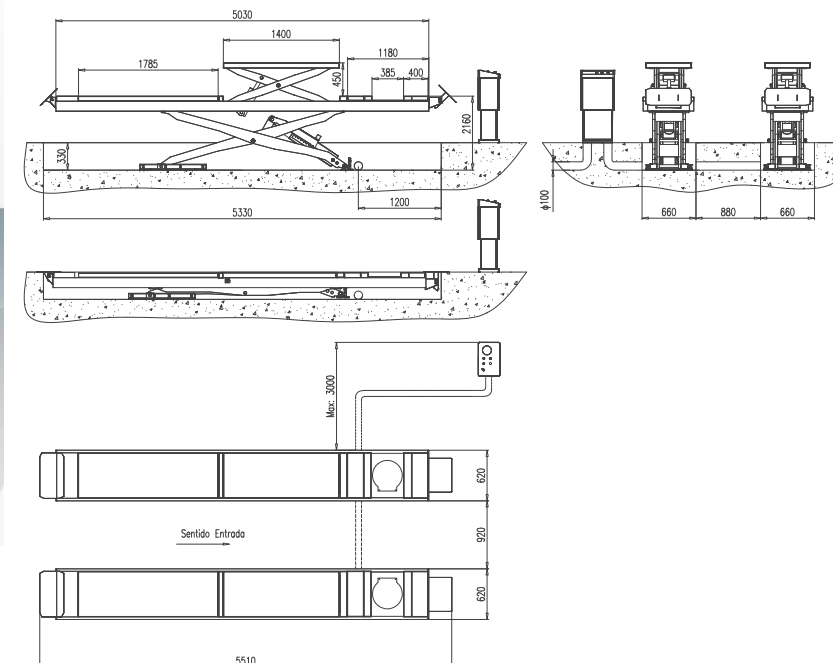

LOW RAISE SCISSOR LIFT 2.800 KG · LOW PROFILE: 105 MM · Mobile version optionals available

MOD. VELYEN | 4EE1150



- Versatility of useful platforms from 1420 mm to 2025 mm.
- Low profile platforms 105 mm suitable for special or tuned vehicles.
- Strong design with two single-effect cylinders for better maintenance
- Mechanical safety system with pneumatic release of safety wedges.
- Safety valve against over-pressure.
- Hydraulic group with gauge cap.
- FreFree maintenance self-lubricating bushings
- Surface installation recommended
- Entry/exit ramps can be used like platforms extensions
- Mechanical device that ensures the synchronization of the platforms height.
- Pushbuttons at 24V, type "dead man"
- Switch On/Off lockable with padlock .
- 100% Safety devices tested at factory before delivery
- Protection against toe-trapping
- Optional accessories for a mobile version permit a quick location of the machine.



Load capacity	2.800 Kg.
Platforms length	Min/max 1.420-2.025 mm
Platforms width	460 mm
Drive on height	105 mm
Maximum lifting height	1.000 mm
Distance between platforms	830 mm
Overall length	2.025 mm
Overall width	1.955 mm
Motor	3 Phase 230/400 V - 50/60 Hz. 2.2 KW

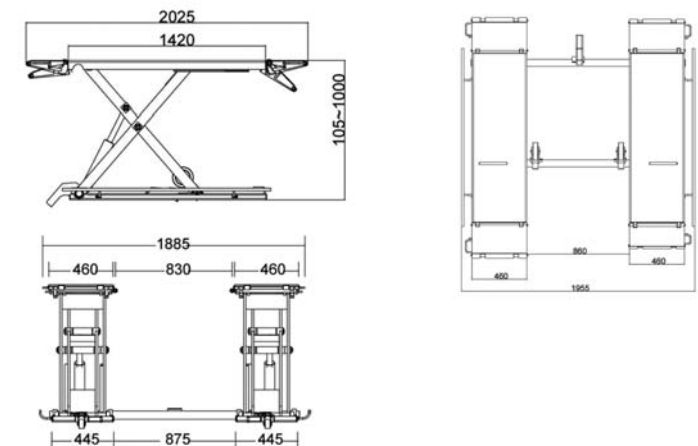

LOW RAISE SCISSOR LIFT 3.000 KG · LOW PROFILE: 105 MM

MOD. VELYEN | 4EE1250



- Strong structure of 4 cylinders to ensure two independent oil circuits: hydraulic safety.
- Additional mechanical safety (ratches) against lowering released by pneumatic device.
- Low profile platforms are suitable for special or tuned vehicles.
- Equipped with flow control valve to adjust the lowering speed.
- Quick bleeding of hydraulic system by handling easily two valves.
- Single phase version (230V) available on order.
- Safety valve against over-pressure
- Suitable for surface or in-ground installation.
- Free maintenance self-lubricating bushings mantenimiento
- Pushbuttons at 24V, type "dead man".
- Isolated ON/OFF switch lockable with padlock.



Load capacity	3.000 Kg.
Platforms Length	Min/max 1.550-2.110 mm
Platforms Width	530 mm
Drive on height	105 mm
Maximum lifting height	1.060 mm
Distance between platforms	800 mm
Overall length	2.118 mm
Overall width	1.860 mm
Motor	3 Phases 230/400 V - 50/60 Hz. 2.2 KW

Single phase version: 4EE1251

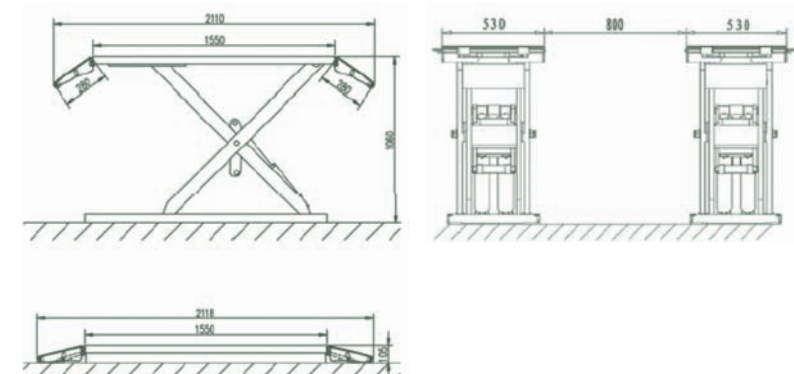

2-RAMS IN-GROUND LIFT WITH PLATFORMS 3.500 KG

MOD. VELYEN | 4EA0500G



- Homologated and certified product according to the European Directive 2006/42/CE
- In-ground piston lift with complete free workplace and minimum space required.
- 4 Aluminium slider plates, length and crosswise adjustable
- Galvanized flan carriers.
- Chromated rams.
- Electronic control with limit switches.
- Acoustic and optic error display.
- Acoustic peep tone against toe-trapping instead of feet protections.
- Ergonomic operating control box.
- Emergency pneumatic lowering system at control site.
- Mechanical synchronization system



Capacity	3.500 Kg
Useful lifting height	1.920 mm
Min. height	60 mm
Raising / lowering time	35 seconds
Motor	3.0 Kw / 400 V / 16 A
Platform width	330 mm
Distance between platforms	1.085 mm
Platforms length	1.450 – 2.050 mm
Distance between pistons	1.335 mm
Piston diameter	123 mm
Cassette dimensions (Large x Width x Height)	1.600 x 400 x 2.338 mm

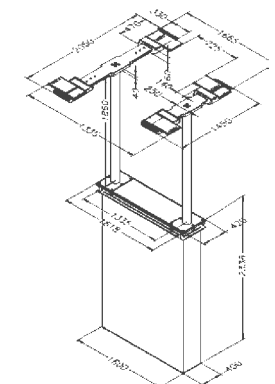
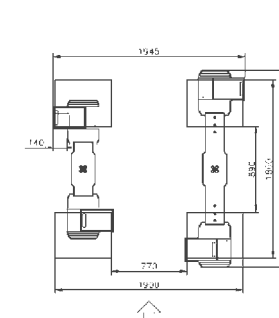

1-RAM IN-GROUND LIFT WITH ARMS · 3.500 Kg

MOD. VELYEN | 4EA0505G



- Homologated and certified product according to the European Directive 2006/42/CE
- In-ground piston lift with complete free workplace and minimum space required.
- 4 telescopic arms, single pivotable with adjustable length
- Galvanized flan carriers.
- Chromated rams.
- Electronic control with limit switches.
- Acoustic and optic error display.
- Acoustic peep tone against toe-trapping instead of feet protections.
- Ergonomic operating control box.
- Emergency pneumatic lowering system at control site.
- Mechanical synchronization system



Capacity	3.500 Kg
Useful lifting height	1.895 mm
Min. height	95 mm
Raising / lowering time	45 seconds
Motor	3.0 Kw / 400 V / 16 A
Arms length	615 – 950 mm
Workplace area	2.125 – 2.200 mm
Installation depth	2.383 mm

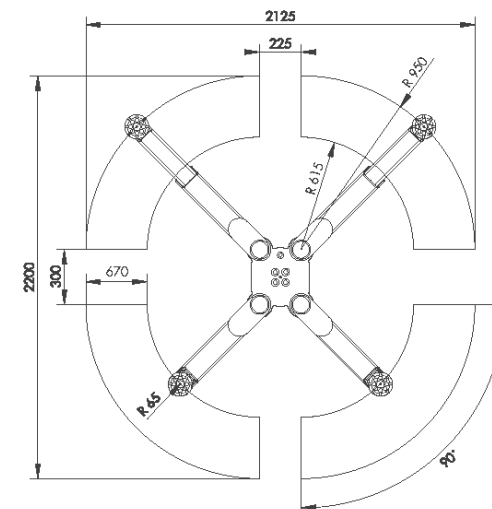

HYDRAULIC MOTORBIKE LIFT 500 KG

MOD. VELYEN | 4EM0351



- Homologated and certified according to the new European Machinery Directive 2006/42/CE and Harmonized Standards EN 1493:2010.
- Mobile equipment that can be easily displaced thanks to its support wheels
- Manual lowering speed control
- High quality hydraulic cylinder
- Lifting speed 20 seconds
- Lowering safety control system
- Anchoring System at different heights
- Safety chain for the front wheel of the bike



Load Capacity	500 kg
Lifting height	1200 mm
Drive on height	200 mm
Platform length	2480 mm
Platform width	820 mm
Overall length	3170 mm
Electrical feature	Single Phase 230 V

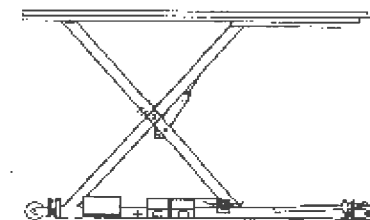
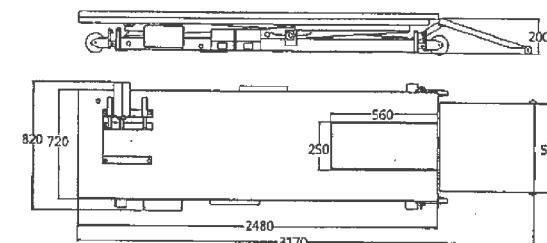

HYDRAULIC 4-POST LIFT 12.000 KG

MOD. VELYEN | 4ED0700N



- Innovative design of columns without longitudinal welds
- Electro-hydraulic lifting system operated over a simple effect cylinder.
- Platform locking system operated automatically by electromagnets
- Safety system against obstacles, cable breakdown or looseness.
- Hidraulic cylinder with control valve of lowering speed.
- Safety valve against overpressure of the hydraulic system
- Motor equipped with thermal detector against overheating
- Pushbuttons at 24V., type "dead man", separated UP & DOWN buttons and ON/OFF switch locable by a padlock.
- Special protection on pulleys zone
- Smooth platforms
- Upper height limit switch.
- Automatic release of safety wedges by pushing DOWN button



Load Capacity	12000 Kg
Platforms width	710 mm
Width between columns	3265 mm
Distance between platforms	(min-max) 780-1150 mm
Drive on height	220 mm
Lifting height	1660 mm
Lifting time	65"
Overall length	7150 mm
Overall width	3735 mm
Motor 4ED0700N	3 Phases 230/400 V - 50 Hz. 3 KW
Motor 4ED0762N	3 Phases 230/400 V - 60 Hz. 3 KW

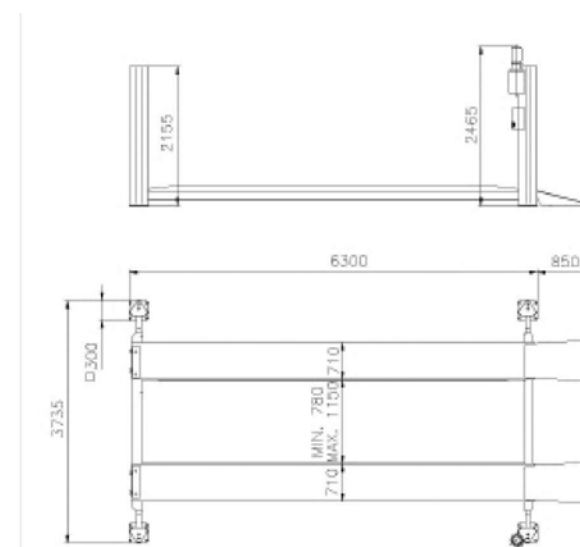

HYDRAULIC 4-POST LIFT 25.000 KG

MOD. VELYEN | 4ED0800



- Innovative design of columns without longitudinal welds
- Electro-hydraulic lifting system operated over a special double piston cylinder.
- Platform locking system operated automatically by electromagnets
- Safety system against obstacles, cable breakdown or looseness.
- Hydraulic cylinder with control valve of lowering speed.
- Safety valve against overpressure of the hydraulic system
- Motor equipped with thermal detector against overheating
- Pushbuttons at 24V., type "dead man", separated UP & DOWN buttons and ON/OFF switch locable by a padlock.
- Special protection on pulleys zone
- Smooth platforms
- Upper height limit switch.
- Automatic release of safety wedges by pushing DOWN button
- International patent on safety and lifting system



Load Capacity	25000 Kg
Platforms width	810 mm
Width between columns	3500 mm
Distance between platforms	1000 mm
Drive on height	240 mm
Lifting height	1540 mm
Lifting time	90"
Overall length	9576 mm
Overall width	4269 mm
Motor 4ED0800	3 Phases 230/400 V - 50 Hz. 5.5 KW
Motor 4ED0862	3 Phases 230/400 V - 60 Hz. 5.5 KW

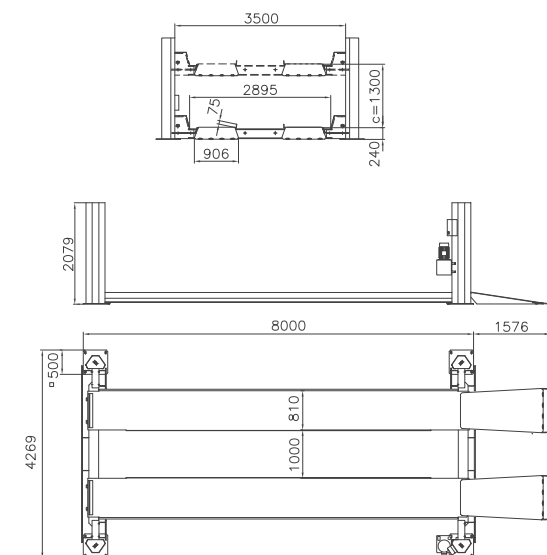

MOBILE COLUMNS LIFT
7.500 KG
MOD. VELYEN | 4EFO100



- Electro-hydraulic columns of 7.500 Kg each.
- Lifting configurations:
 - 4-columns set: 1 master + 3 slave columns
 - 6-columns set: 1 master + 5 slave columns
- Interconnecting cables from column to column around the vehicle in a cable circuit with one open end to drive in/out.
- Adjustable wheel forks from 380 to 620 mm.
- Each slave column is equipped with interconnecting cable with plugs at both ends.
- The control system "SCS" guarantee perfect and smooth synchronization of the lifting columns without speed variations and a continuous monitoring of all functions
- Optional wireless remote control.
- Individual hydraulic wheel jack on each column permits an easy and quick position.
- Lifting columns can be operated individually or all together.
- Safety system against obstacles.
- Mechanical upper height limit stop to protect the piston travel.
- Flow valve to control the lowering speed.
- Safety valve against over-pressure.



ELEVADOR PRINCIPAL

Load capacity	7500 Kg per column
Wheel forks length	320 mm
Wheel forks width	380-620 mm
Column height	2300 mm
Overall length	1275 mm
Overall width	1100 mm
Overall height	3655 mm
Lifting stroke	1800 mm
Lifting time	82"
Motor	3 Phase 400 V - 50 Hz. 2,2 Kw / Column
Weight	500 Kg

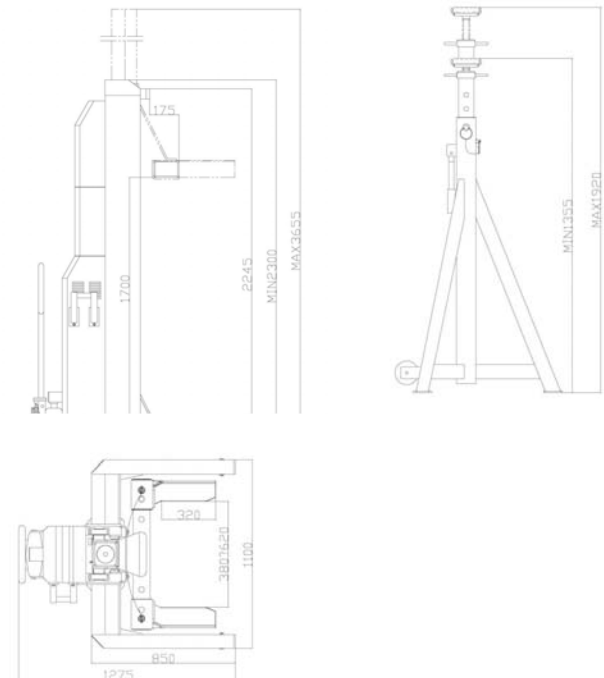

▶ **TIRE EQUIPMENT**

AUTOMATIC TIRE CHANGER 2 SPEED 23"

MOD. VELYEN | 4RA0505



- Machines designed to provide high performances
- Engineering quality guaranteed
- Two turntable speeds on the same pedal
- Pneumatic tire placing with helper arm
- High resistance vertical column with AUTOMATIC back-ward
- Exclusive and high quality connecting rods (self-centered turntable and same tightly strength for any wheel diameter)
- Equipped with plastic protectors and inflating gum
- Manometer-lubricator and filter with gauge
- Motorbike optional available on order
- Optional plastic body for mounting/demounting tool



Internal rim clamping	12" - 23"
External rim clamping	10" - 20"
Maximum tire diameter	1040 mm
Maximum tire width	350 mm
Turntable thickness	12 mm
Designed for	Workshops tires working
Option Arm Auxiliary	1 Generation

Electrical version - Motor	4RA0505 - 3 Phases 1 Kw; 400V; 50/60Hz
	4RA1523 - 3 Phases 1 Kw; 230V; 50/60Hz
	4RA1551 - Single Phase; 230V; 50/60Hz
Rapid inflation version tubeless tire	4RA0505i
	4RA1523i
	4RA1551i

OPTIONALS

4800165	Pneumatic Helper Arm for Run Flat tires
4800900	Motorcycle Tires Adapter 5" - 25"



AUTOMATIC ELECTRONIC WHEEL BALANCER 24"

MOD. VELYEN | 4RB0051



- External measurement calliper included
- Wheel hood works as START & STOP button while balancing the wheel pulling the hood down and up
- Maximum wheel weight 65 Kg.
- Manual wheel geometric data input
- Unit system selection: milimetre/inch & gram/ounce
- Ø36mm balance shaft diameter
- Latest generation software
- Static and Dynamic balancing programs (STA/DYN)
- Emergency Stop Pushbutton
- Motorbike balancing program
- Wheel hood included



Rim Diameter	10" - 24"
Rim Width	1.5" - 20"
Noise	<69dB
Max wheel diameter	1110 mm
Max wheel weight	65 Kg
Accuracy	1 g
Motor	Single Phase 230V - 50/60 Hz - 0,25 Kw
Designed for	Independent Workshops
Standard Fittings	Cone kit (3 units from Ø 40 to Ø157), butterfly nut and fixing pin

OPTIONALS

4803802	Adapter for Motorcycles
4803301	Blind Tires car Adapter

► AUTOMATIC WHEEL BALANCER 28"

4RB0251A

VelyenPremium

velyen licensed by
ISTOBAL

Especialistas en Posventa - Equipamiento de taller



Heavy Duty Wheel Balancer Professional



Features:

- Automatic data entry system of distance and rim diameter.
- External gauge to automatically store also the width diameter.
- Rim diameter measurable with internal digital gauge.
- Automatic brake to stop the wheel after balancing process.
- STOP pushbutton to get the immediate stop of the machine.
- Ideal to be used in professional tire workshops.
- Equipped with automatic balancing cycle activated pulling down the wheel hood.
- Static and dynamic balancing mode.
- 7 ALU programs dedicated to alloy rims, including 2 ALU-Precision programs.
- 3 motorcycle balancing programs (dynamic, ALU, and "Split Moto")
- Self-calibration and Self-diagnosis programs.

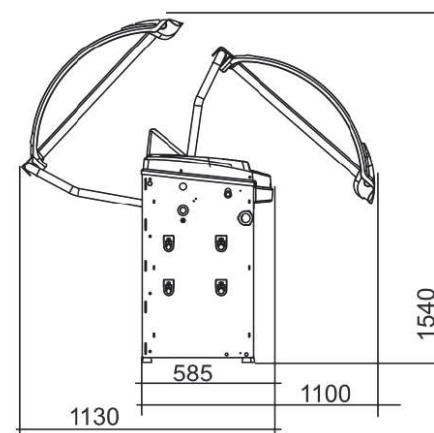
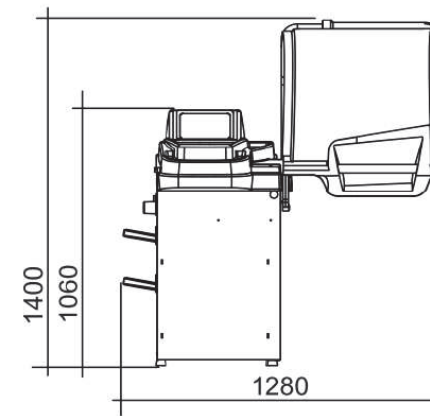

TECHNICAL DATA

Rim diameter	11" - 28"
Rim width	1.5" - 20"
Noise level	70dB
Max wheel diamet	1117 mm
Max wheel weight	75 Kg
Balacing precision	1 g
Power Supply	Single Phase 230V 50/60 Hz - 0,1 Kw
Designed for	Professional tire workshop
Accessories	3 cones Ø 40 - 111
	Fixing butterfly
	CompasFFF

OPTIONAL ACCESSORIES

4803801	Adapter for motorcycles
4803300	Universal quick adapter for 3-4-5-6 holes wheels (wheels without central hole)
4803600	Cone for Ø 120-170 mm
4803137	Cone set 95-137 mm

CE

PROFESSIONAL AUTOMATIC WHEEL BALANCER 30"

MOD. VELYEN | 4RB2051



- Max rim diameter measurable with the internal digital gauge of 28"
- AUTOMATIC SEARCH of the balancing position
- Electronic shaft locking system
- STOP pushbutton to get the immediate stop of the machine
- Ideal to be used in professional tyre workshops
- Equipped with automatic balancing cycle activated pulling down the wheel hood
- Automatic data entry system of distance and rim diameter
- External gauge available on demand to automatically store also the wheel width parameter



Rim Diameter	10" - 30"
Rim Width	1.5" - 20"
Motor	Single Phase 230V - 50/60 Hz
Max wheel weight	75 Kg
Max wheel diameter	1190 mm
Accuracy	1 g
Balancing speed	Commercial Vehicle: 200 rpm Light Truck: 140 rpm

OPTIONALS

4803800	Adapter for Motorcycles
4803300	Blind Tires car Adapter
4803137	Cones 4x4 Kit 95-137 mm

► WHEEL ALIGNERS

velyen licensed by **ISTOBAL**

Automotive Lifting Quality

WHEEL ALIGNER RADIO 2.4 GHZ

MOD. VELYEN | 4RC0190



- 4 measuring heads with 8 CCD cameras (communication between measuring heads by infrared sensors)
- Transmission data system wireless with RADIO 2,4 GHz.
- Data base with more than 19.000 vehicles subdivided by geographical zones
- Suitable to perform a professional wheel alignment adjustments with clear and complete information to meet car manufacturer recommendations
- Available 2 programs ROC to compensate run-out problems and mistakes caused by a wrong coupling between rim and clamp
- Standard machine supplied with 4 measuring heads equipped with 8 CCD cameras, 4 auxiliary measuring heads cables, 1 steering wheel holder and 1 pedal depressor PFR.



STANDARD SPECIFICATIONS
Transmission data system by radio
4-point clamps (10" – 21")
Turntables 1.5 Tn
External battery recharger
Cabinet with monitor LCD 19" and printer
230/110V - 50/60 Hz - 500W

OPTIONALS
4-points clamps (10"-26")
4-points clamps extensions up to 26"
3-points clamps (10"-21")
Turntables 4 Tn
Simulator frame for measuring head calibration
Truck kit

Advantages:

- Measurements in driving position, it is not necessary to lift the wheels
- For mobile use, regardless of the place.
- Easy-to-use software, fast and flexible.
- Especially useful for vehicles with multi directional axles.
- Rapid measurement of convergence, camber, caster, and directional angle of the axles
- High performance at a reasonable price that ensures a rapid return on investment.

WHEEL ALIGNER RADIO 2.4 GHZ

MOD. VELYEN | 4RC0200A



- 4 measuring heads with 8 CCD cameras (communication between measuring heads by infra-red sensors)
- Transmission data system wireless with RADIO 2,4 GHz.
- Data base with more than 19.000 vehicles subdivided by geographical zones
- Suitable to perform a professional wheel alignment adjustments with clear and complete information to meet car manufacturer recommendations
- Available 2 programs ROC to compensate run-out problems and mistakes caused by a wrong coupling between rim and clamp
- Standard machine supplied with 4 measuring heads equipped with 8 CCD cameras, 4 auxiliary measuring heads cables, 1 steering wheel holder and 1 pedal depressor PFR.



STANDARD SPECIFICATIONS
Transmission data system by radio
4-point clamps (10" – 21 ")
Turntables 1.5 Tn
External battery recharger
Cabinet with monitor LCD 19" and printer
230/110V - 50/60 Hz - 500W

OPTIONALS
4-points clamps (10"-26")
4-points clamps extensions up to 26"
3-points clamps (10"-21")
Turntables 4 Tn
Simulator frame for measuring head calibration
Truck kit Mod. 991100

Advantages:

- Measurements in driving position, it is not necessary to lift the wheels
- For mobile use, regardless of the place.
- Easy-to-use software, fast and flexible.
- Especially useful for vehicles with multi directional axles.
- Rapid measurement of convergence, camber, caster, and directional angle of the axles
- High performance at a reasonable price that ensures a rapid return on investment.

► WHEEL ALIGNERS

vrellyen licensed by **ISTOBAL**

Automotive Lifting Quality

3D WHEEL ALIGNER

MOD. VELYEN | 4RC0300



- The 4RC0300 is a 3D wheel aligner with PC (Windows), 19" colour monitor and ink jet printer. Based onto powerful ULTRA camera technology.
- All the most important vehicle angles can be measured in a fast and easy way just by following the guided software procedure.
- Easy to use in 3 simple steps also for those who are not familiar with 3D technology:
 1. Fit the clamps to the wheels
 2. Roll the vehicle back and forth
 3. Get the readings in the monitor
- Camera beam lift with 2 moveable cameras can be easily adjusted up to 2 meters for a comfortable attachment of clamps.
- In less than 3 minutes the 4RC0300 aligner provides highly accurate measurement of alignment data and attractive visual representation of settings.
- The 4RC0300 aligner provides measurements, procedures and adjustments specified by OEMs world-wide, ensuring the vehicle is maintained to exact original specifications.
- Updated database with more than 20.000 car models over the past 25 years
- The innovative space-saving design allows use even in small garages and workshops.
- The ergonomic control terminal can be fitted on the camera lift or on a socket supplied with the aligner.



EQUIPAMIENTO DE SERIE

Universal wheel clamps 11"-22"

Mobile basic cabinet

Steering wheel holder

PC (Windows) with keyboard & mouse

Loudspeaker

Colour monitor 19" TFT

Brake pedal depressor

Colour ink jet printer DIN A4

· Wireless remote control

Camera beam lift with 2 moveable cameras

2 front turnplates

Software package with vehicle data base

OPCIONALES

26" Universal wheel clamp extension

Aligner platform

Kit of 4 tire clamps

AUTOMATIC 3-PHASE TIRE CHANGER UP TO INTERNAL CLAMPING 26"

MOD. VELYEN | 4RA0600



- The universal electro-hydraulic tire changer is suitable to handle truck and bus tires.
- The self-centering chuck locks grooved and split ring rims from 14" to 26".
- The machine performs the following automation level:
 - Rotation in both directions of the self-centering chuck;
 - Fixed chuck-holder arm;
 - Automatic traversing movement of the bed breaker arm.
 - Manual lifting and manual traversing movement in 2 different positions of the breaker arm.



Internal Clamping	14" - 26"
Max Wheel Diameter	1600 mm
Max Wheel Width	780 mm
Hydraulic Motor	3-Phase 400V - 1.1 KW
Reduction Motor	3-Phase 400V - 1.5 KW

OPTIONALS

4802800	Aluminium Rim Protector
---------	-------------------------

AUTOMATIC 3-PHASE TIRE CHANGER UP TO INTERNAL CLAMPING 56"

MOD. VELYEN | 4RA0800



- Automatic electro-hydraulic tire changer specifically designed for intensive and professional purposes, suitable for disassembly and assembly of the wheels of commercial vehicles, trucks, buses, tractors and earthmoving machines.
- The self-centering chuck locks grooved and split ring rims from 14" to 56".
- In order to minimize the working time, all movements are dual speed, fully automated:
 - 1) Double rotation speed in the two directions of self-centered
 - 2) Automatic transverse movement of wheel carrier tower.
 - 3) Wheel carrier tower lifting controlled by the control unit
 - 4) Double speed of the wheel carrier tower during its transverse movement
 - 5) Rotation of wheel carrier tower controlled by the control unit

CE



Internal Clamping	14-56" (de 34" a 56" with extensions)
Max Wheel Diameter	2.450 mm
Max Wheel Width	1.220 mm
Max Wheel Weight	1.300 Kgs
Motor	2 Kw
Reduction Motor	1.3-1.8 Kw
Designed for	Profesional Tire Workshops for Trucks

MANUAL WHEEL BALANCER FOR COMMERCIAL VEHICLES UP TO 28"

MOD. VELYEN | 4RB0551



- Shaft Diameter 40mm
- Latest Generation Software
- Suitable to customize the display, the key functions and language
- External scale available to automatically add the wheel width data.
- Automatic search for the correct balanced position
- Launches counter and program to correct the eccentricity of the wheel
- Wheel hood included
- Standard fittings as cones and butterfly nut included.



Clamping Capacity	8" - 20" light vehicles / 12" - 28" heavy vehicles
Rim Width	1.5" - 16" light vehicles / 4" - 20" heavy vehicles
Motor	Single Phase 230V - 0.16 KW
Max Wheel Weight	200 Kg
Max Wheel Diameter	1320 mm
Max Wheel Width	800 mm
Balance Speed	Light Vehicles: 120 rpm Heavy Vehicles: 80 rpm

OPTIONALS

4804700	Cone Kit Ø 47 - 165 mm
----------------	------------------------

AUTOMATIC WHEEL BALANCER FOR COMMERCIAL VEHICLES UP TO 30"

MOD. VELYEN | 4RB0651



- Electronic wheel balancer with 19" LCD monitor
- Suitable for both, passenger cars and commercial vehicles thank to different programs:
 1. TRUCK PROGRAM for heavy commercial vehicles
 2. CAR PROGRAM for passenger cars and light commercial vehicles.
- This wheel balancer, designed for professional purposes, is equipped with an automatic sensor to search the right balancing position and activate the balancing cycle.
- Also provided with a rich endowment of software that can operate on all wheels on the market:
 1. Automatic detection of wheel (car or truck)
 2. Automatic correction of the imbalance position on both sides
 3. 7 ALU programs dedicated to alloy rims
 4. Quick optimization program calculates the best coupling configuration between rim and tyre in order to minimize the overall wheel imbalance, thus reducing vehicle running noise and perceived vibration levels.
 5. Hidden Weight and Shift Plane programs for aluminum rims
 6. Multi-operator development
 7. Suitable to customize the display, the key functions and language



Clamping Capacity	7" - 30" light vehicles / 12" - 30" heavy vehicles
Rim Width	1.5" - 22" light vehicles / 4" - 22" heavy vehicles
Motor	Single Phase 230V - 0.22 KW
Max Wheel Weight	200 Kg
Max Wheel Diameter	1220 mm
Max Wheel Width	700 mm
Balance Speed	Light Vehicles: 120 rpm Heavy Vehicles: 80 rpm

OPCIONALES

4804700	Cone Kit Ø 47 - 165 mm
---------	------------------------



SPAIN

Parque Industrial Ciudad de Carlet
C/ Camino del Carrasqueral, N° 6
46240 Carlet - Valencia (Spain)
T (+34) 96 253 82 28 · Fx (+34) 96 254 30 74

www.velyen.com